

INDUSTRY NINE SERVICE GUIDE

1/1 MOUNTAIN REAR HUB SERVICE

Industry Nine products are designed to keep you in the saddle and out of the service queue. Regular service and maintenance is simple and can be performed with basic tools readily available to the home or shop mechanic - *no proprietary tools are required.*

To properly service your Industry Nine 1/1 series hubs, please follow the steps below.

For more information: Call 828-210-5113, email service@industrynine.com or visit industrynine.com/support

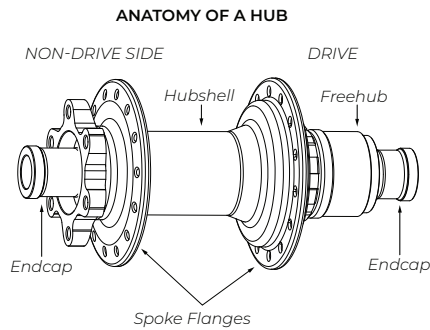

TOOLS
RUBBER / PLASTIC MALLET



BEARING LAYOUT CHART

HUBSHELL	DRIVE SIDE	NON-DRIVE SIDE
6 Bolt Mountain Front	1 x 18307	1 x 18307
6 Bolt Mountain Rear	1 x 15307	1 x 15307
Center Lock Mountain Front	1 x 18307	1 x 18307
Center Lock Mountain Rear	1 x 15307	1 x 15307
FREEHUB	INBOARD	OUTBOARD
Hydra XD + HC	1 x 152610	1 x 15267
Micro Spline	1 x 152610	2 x 6802

PRO TIPS: If you are having trouble getting the endcaps off, a (non-marring) soft jawed vice or soft jawed pliers can be used for removal.*

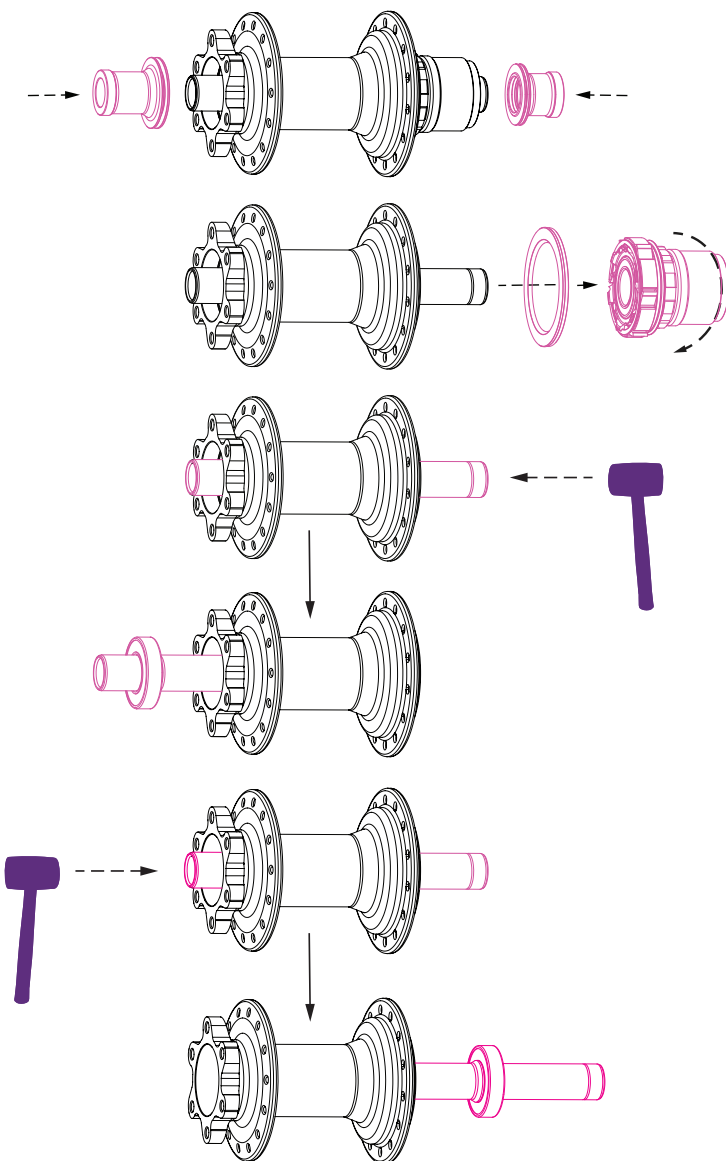

1.1 Rear Hub Disassembly - To disassemble your 1/1 hubs you need to first remove the **endcaps** from the axle. The **endcaps** are held in place with a rubber o-ring seated in the endcap. Endcaps do not require tools for removal.*

1.2 Freehub Removal - Once the endcaps are removed, the **freehub** can be pulled off by hand. Hold the wheel with the **freehub** facing down, as it disengages from the driving. Rotate the wheel counterclockwise while gently pulling outward. You can then pry the seal out gently.

1.3 Rear Hub Axle + Bearing Removal - With both endcaps and the freehub are removed you will be left with an **axle** that is exposed on both sides.

Tap with a **mallet** from either side to dislodge the bearing and **axle** from the opposite side. The axle has shoulders that contact the inner race of the bearing, and will drive the bearing out of the hubshell. The order in which you remove the bearings does not matter.

Reinsert the **axle** and use it to drive out the remaining bearing in the same manner you removed the first. The remaining bearing can also be removed with a blind bearing puller or carefully with a drift/punch and a mallet.

INDUSTRY NINE SERVICE GUIDE

1/1 MOUNTAIN REAR HUB SERVICE

PRO TIPS:

- *Reference Bearing Layout Chart for proper bearing size by hubshell type.
- Note grey side of bearing is designed to face outward from the product.
- To re-assemble, follow reverse order from disassembly. Take care to put all bearings in as straight as possible.
- You can install the bearings with a threaded rod bearing press, an arbor press, or a vice may be used to press the bearings in evenly and without impact.

TOOLS
BEARING PRESS



BEARING LAYOUT CHART

HUSHELL	DRIVE SIDE	NON-DRIVE SIDE
6 Bolt Mountain Front	1 x 18307	1 x 18307
6 Bolt Mountain Rear	1 x 15307	1 x 15307
Center Lock Mountain Front	1 x 18307	1 x 18307
Center Lock Mountain Rear	1 x 15307	1 x 15307

FREEHUB	INBOARD	OUTBOARD
Hydra XD + HG	1 x 152610	1 x 15267
Micro Spline	1 x 152610	2 x 6802

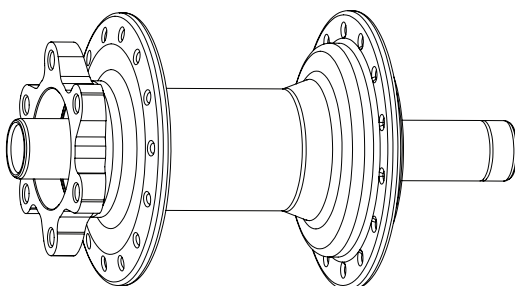
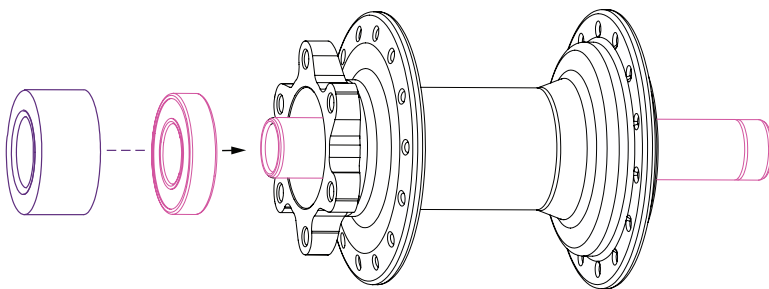
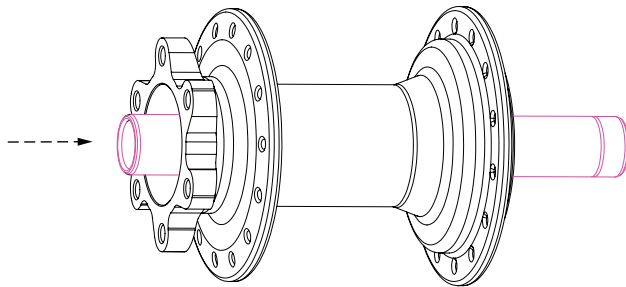
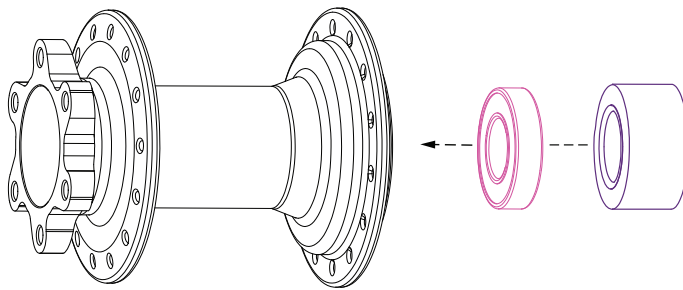

1.4 Rear Hub Assembly - Start by lining the inside of your clean bearing bores with a thin film of grease, then press the **drive side bearing** into the drive side of the hub using a **bearing press**.

After the drive side bearing has been pressed in, insert the hub's **axle** through from the NON-DRIVE side of the hub.

Press the **non-drive side bearing** over the end of the **axle**, into the NON-DRIVE side of the hubshell.

This will leave you with a hubshell that has an axle held captive by the two bearings.*

INDUSTRY NINE SERVICE GUIDE

1/1 MOUNTAIN REAR HUB SERVICE

PRO TIPS:

· Try to maintain perpendicularly to the bearing bore when removing bearings.

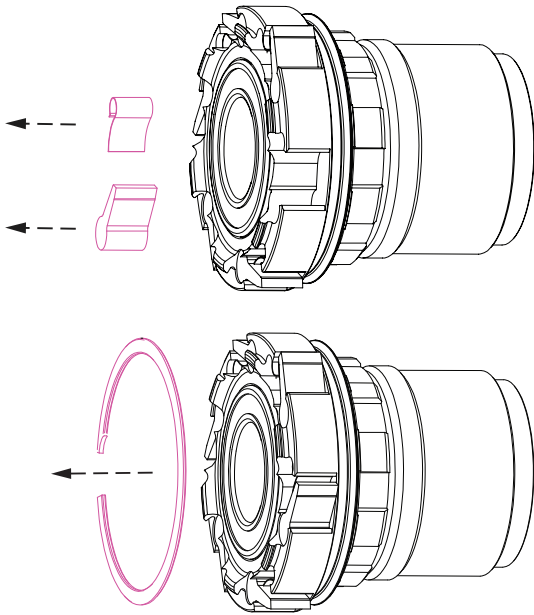

2.1 Freehub Disassembly +

Service - To access the pawls and springs, you must first remove the retaining clip on the inside face of the Freehub body. After that, those components are easily removed by hand. The **pawls** and **springs** should easily slide out of the pawl and spring pockets.

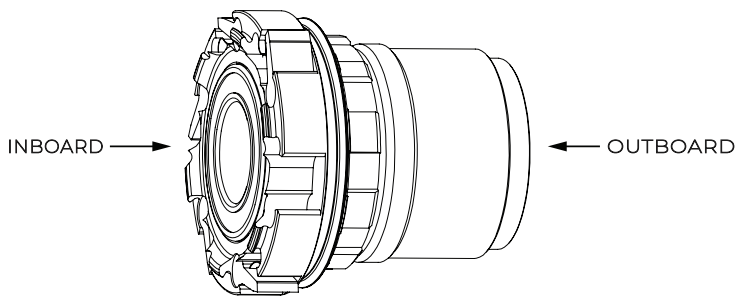

2.2 Freehub Bearing Removal

Once the drive components are removed from the freehub shell there will be 1 **inboard** and 1 or 2 **outboard** bearings (depending on the freehub type) with a **cylindrical spacer** between them. The cylindrical spacer can be shifted out of the way to access the inner race.

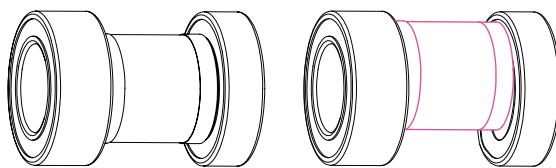

INTERNAL VIEW

Careful removal of one of these bearings (the order doesn't matter) with a blind bearing puller or tapped out with a drift or a punch will remove the bearing, allowing the spacer to be withdrawn. The remaining bearing should be removed in the same manner.

INDUSTRY NINE SERVICE GUIDE

1/1 MOUNTAIN REAR HUB SERVICE

PRO TIPS:

- *Reference Bearing Layout Chart for proper bearing size by hubshell type.
- Note grey side of bearing is designed to face outward from the product.
- To re-assemble, follow reverse order from disassembly. Take care to put all bearings in as straight as possible.
- You can install the bearings with a threaded rod bearing press, an arbor press, or a vice may be used to press the bearings in evenly and without impact.
- If there is additional drag found after assembly, it might be a result of an improper seal installation.
- Make sure to properly clean and lubricate all interfaces between parts before reassembly.

TOOLS BEARING PRESS



BEARING LAYOUT CHART

HUSHELL	DRIVE SIDE	NON-DRIVE SIDE
6 Bolt Mountain Front	1 x 18307	1 x 18307
6 Bolt Mountain Rear	1 x 15307	1 x 15307
Center Lock Mountain Front	1 x 18307	1 x 18307
Center Lock Mountain Rear	1 x 15307	1 x 15307

FREEHUB	INBOARD	OUTBOARD
Hydra XD + HG	1 x 152610	1 x 15267
Micro Spline	1 x 152610	2 x 6802

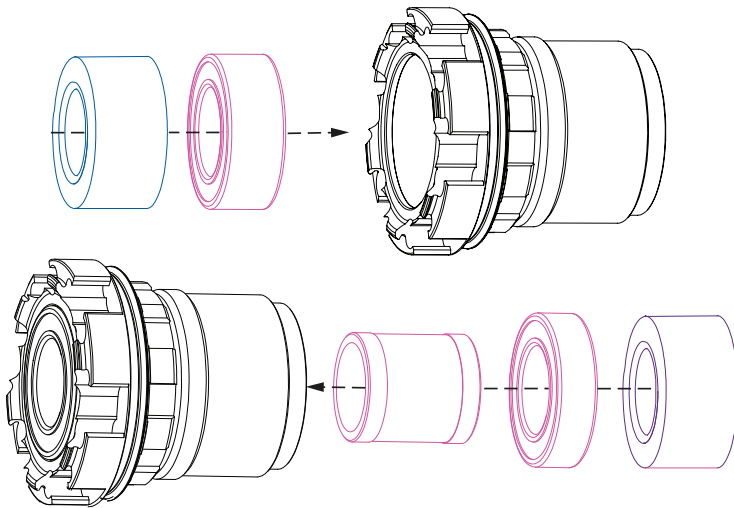

4.1 Inboard Freehub Bearing Assembly

Start by pressing the **inboard double row bearing** into the inboard side of the freehub using a bearing press.

4.2 Outboard Freehub Bearing Assembly

Place the **inboard double row bearing** in between the two bearings. Press the outboard side bearing into the outboard side of the freehub.

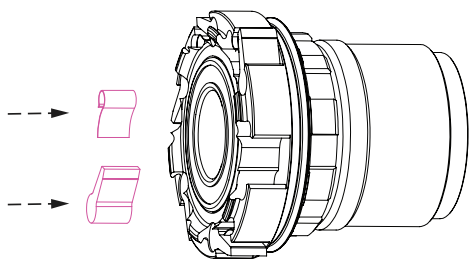

4.3 Spring and Pawl Assembly

The **spring** and **pawl** and slide into the pawl and spring pockets. Insert spring first, depress spring with pick to insert pawl.

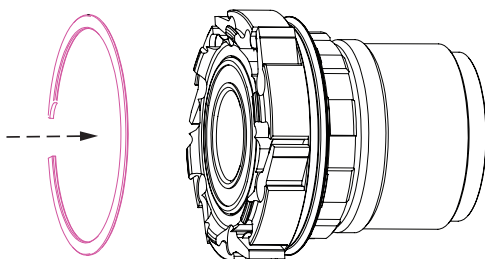

4.4 Retaining Clip

After installing the freehub's **spring and pawl**, you will need to install the pawl and spring retaining clip. It shouldn't require much force to install it, and should fit onto the outside the securing protrusions on the top of the freehub body.

INDUSTRY NINE SERVICE GUIDE

1/1 MOUNTAIN REAR HUB SERVICE

PRO TIPS:

- Apply grease to driving and pawls to quiet the freehub sound.
- Apply oil to driving and pawls to increase the freehub sound.
- Make sure to properly clean and lubricate all interfaces between parts before reassembly.

TOOLS

DUMONDE TECH FREEHUB GREASE + OIL

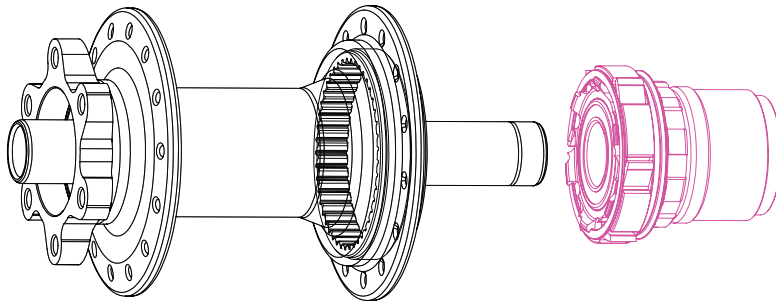

4.3 Freehub Installation on Hubshell

Apply a small amount of Dumonde Tech freehub grease to the driving face of every other pawl, as well as a small amount on the driving itself. Apply a drop of oil to the freehub seal.

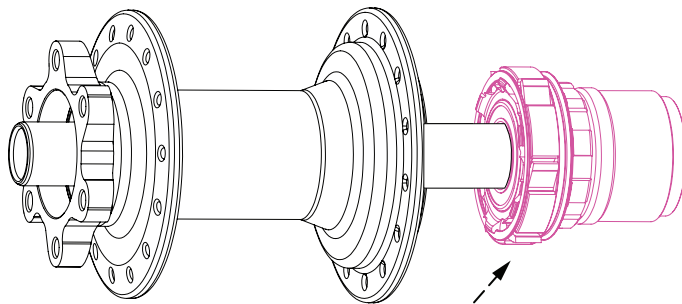

Push the **freehub** onto the axle. Be sure that the freehub's **inner spacer** is centered, then slide the freehub over the axle onto the rear hub's drive side.

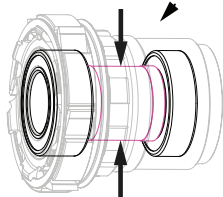

You will need to center the **cylindrical spacer** with your finger to in order for it to slide onto the axle.

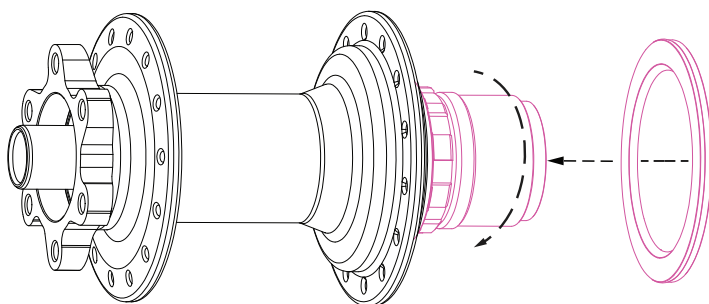

Once the **freehub** makes contact with the driving gently press the **freehub** onto the hub while twisting it counter-clockwise to engage the pawls into the driving. After this step, the freehub seal can be gently pressed into place by hand. It should fit snug between the freehub body and the hub shell.

INDUSTRY NINE SERVICE GUIDE

1/1 MOUNTAIN REAR HUB SERVICE

PRO TIPS:

· Make sure to properly clean and lubricate all interfaces between parts before reassembly.

TOOLS

MARINE GREASE

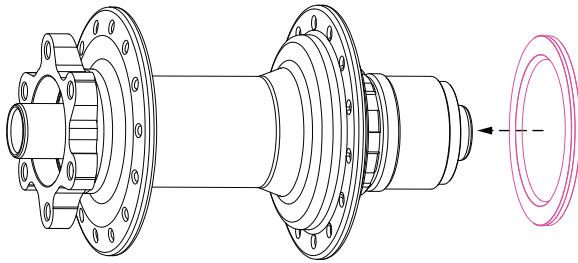

5.1 Endcaps + Final Rear Hub Assembly - With the bearings, axle, and freehub installed you can now install the endcaps onto the axle to have a fully functional hub.

Put a film of marine grade (preferably) or other waterproof grease onto the front face of the **bearing seal** before installing.

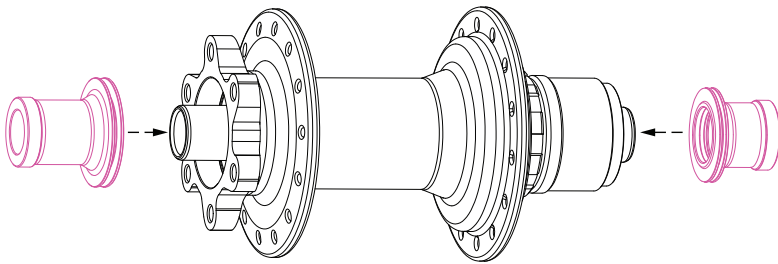

When you push the **endcap** on, grease may get pushed out of the edges. The marine grease, creates a membrane that will help keep your bearings from contamination that could reduce bearing life.

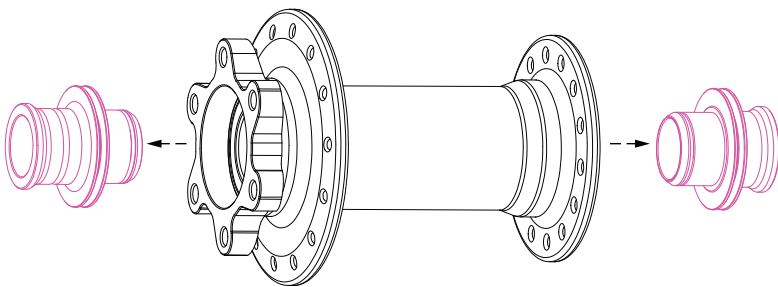

6.1 Front Hub Disassembly - The front hub consists of a cylindrical axle spacer held in place by two bearings and two endcaps pressed onto each side.

The front hub's **endcaps** are held in place with an o-ring seated in the endcap.

The endcaps can be removed with a light tug. If more force is needed, protect the end cap with an axle vice or shop rag and pull off with a vice or pliers. Be careful not to damage the face that makes contact with your fork!

INDUSTRY NINE SERVICE GUIDE

1/1 MOUNTAIN FRONT HUB SERVICE

PRO TIPS:

- *Reference Bearing Layout Chart for proper bearing size by hubshell type.
- Note grey side of bearing is designed to face outward from the product.
- To re-assemble, follow reverse order from disassembly. Take care to put all bearings in as straight as possible.
- You can install the bearings with a threaded rod bearing press, an arbor press, or a vice may be used to press the bearings in evenly and without impact.
- Make sure to properly clean and lubricate all interfaces between parts before reassembly.

TOOLS

BEARING PRESS



BEARING LAYOUT CHART

HUSHELL	DRIVE SIDE	NON-DRIVE SIDE
6 Bolt Mountain Front	1 x 18307	1 x 18307
6 Bolt Mountain Rear	1 x 15307	1 x 15307
Center Lock Mountain Front	1 x 18307	1 x 18307
Center Lock Mountain Rear	1 x 15307	1 x 15307

FREEHUB	INBOARD	OUTBOARD
Hydra XD + HG	1 x 152610	1 x 15267
Micro Spline	1 x 152610	2 x 6802

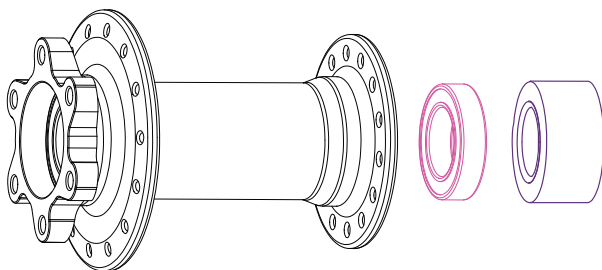
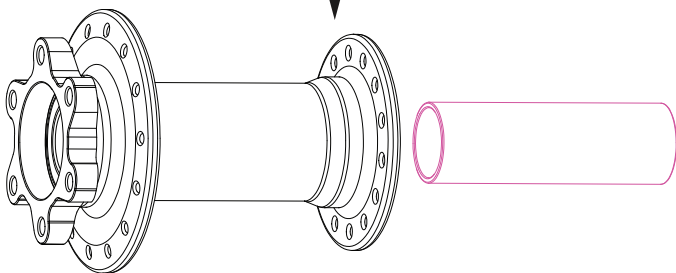
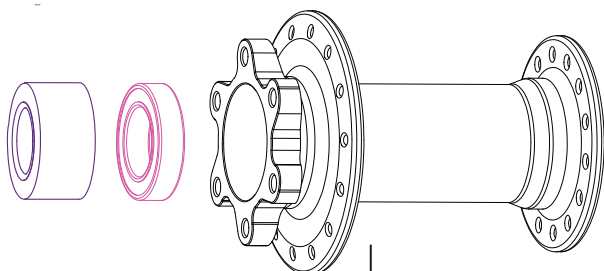
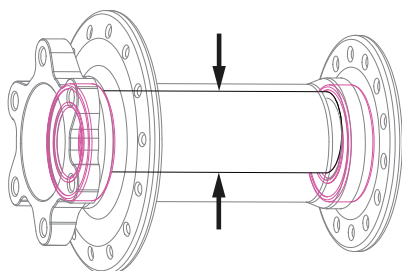

6.2 Front Hub Bearing Removal -

With the hub's end caps removed, there will be two bearings on each side with a spacer held captive in between them.

In order to remove a bearing you will need to cock the inner spacer to one side or another to expose the inner race of the bearing. This allows you to remove the bearings with a blind bearing puller or tapped out with a drift/punch.

If using a drift or a punch to knock the bearings out, be sure to alternate sides so that it is removed as evenly as possible. Once one bearing is removed (the order of removal does not matter) the spacer will fall out. The remaining bearing should be removed in the same way.

7.1 Front Hub Assembly - Front Hub Assembly - Press one bearing into the front hubshell. The side you choose first does not matter.

Insert the inner spacer into the hubshell. Make sure that the inner spacer's o-rings are seated properly.

Press the second bearing into the other side. using a threaded rod bearing press, arbor press, or vice. Press the bearings in evenly and without impact.

INDUSTRY NINE SERVICE GUIDE

1/1 MOUNTAIN FRONT HUB SERVICE

PRO TIPS:

- *Reference Bearing Layout Chart for proper bearing size by hubshell type.
- Note grey side of bearing is designed to face outward from the product.
- To re-assemble, follow reverse order from disassembly. Take care to put all bearings in as straight as possible.
- You can install the bearings with a threaded rod bearing press, an arbor press, or a vice may be used to press the bearings in evenly and without impact.
- Make sure to properly clean and lubricate all interfaces between parts before reassembly.

TOOLS

BEARING PRESS



BEARING LAYOUT CHART

HUSHELL	DRIVE SIDE	NON-DRIVE SIDE
6 Bolt Mountain Front	1 x 18307	1 x 18307
6 Bolt Mountain Rear	1 x 15307	1 x 15307
Center Lock Mountain Front	1 x 18307	1 x 18307
Center Lock Mountain Rear	1 x 15307	1 x 15307

FREEHUB	INBOARD	OUTBOARD
Hydra XD + HG	1 x 152610	1 x 15267
Micro Spline	1 x 152610	2 x 6802

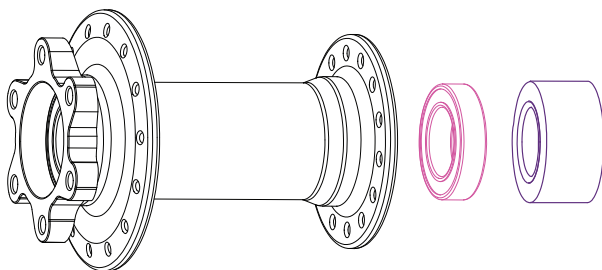
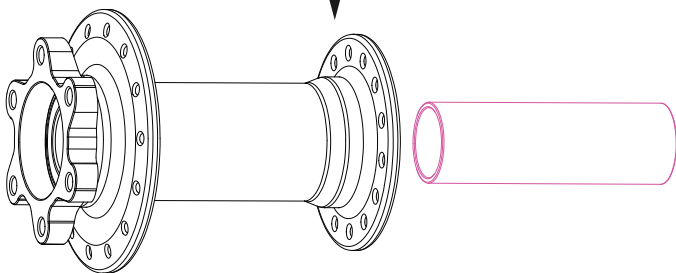
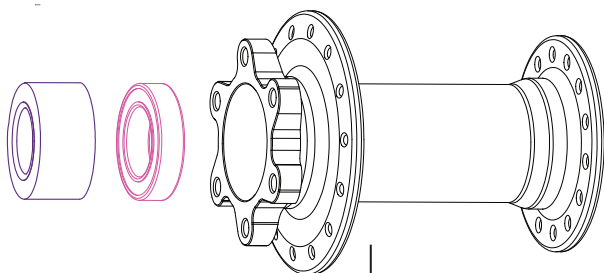
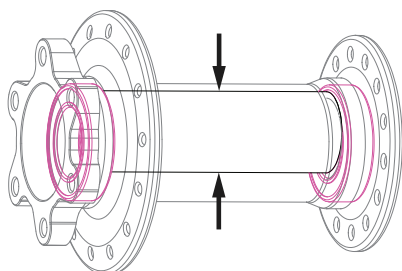

6.2 Front Hub Bearing Removal -

With the hub's end caps removed, there will be two bearings on each side with a spacer held captive in between them.

In order to remove a bearing you will need to cock the inner spacer to one side or another to expose the inner race of the bearing. This allows you to remove the bearings with a blind bearing puller or tapped out with a drift/punch.

If using a drift or a punch to knock the bearings out, be sure to alternate sides so that it is removed as evenly as possible. Once one bearing is removed (the order of removal does not matter) the spacer will fall out. The remaining bearing should be removed in the same way.

7.1 Front Hub Assembly - Front Hub Assembly - Press one bearing into the front hubshell. The side you choose first does not matter.

Insert the inner spacer into the hubshell. Make sure that the inner spacer's o-rings are seated properly.

Press the second bearing into the other side. using a threaded rod bearing press, arbor press, or vice. Press the bearings in evenly and without impact.

INDUSTRY NINE SERVICE GUIDE

1/1 MOUNTAIN FRONT HUB SERVICE

PRO TIPS:

- *Reference Bearing Layout Chart for proper bearing size by hubshell type.
- Note grey side of bearing is designed to face outward from the product.
- To re-assemble, follow reverse order from disassembly. Take care to put all bearings in as straight as possible.
- You can install the bearings with a threaded rod bearing press, an arbor press, or a vice may be used to press the bearings in evenly and without impact.

TOOLS

BEARING PRESS



BEARING LAYOUT CHART

HUBSHELL	DRIVE SIDE	NON-DRIVE SIDE
6 Bolt Mountain Front	1 x 18307	1 x 18307
6 Bolt Mountain Rear	1 x 15307	1 x 15307
Center Lock Mountain Front	1 x 18307	1 x 18307
Center Lock Mountain Rear	1 x 15307	1 x 15307

FREEHUB	INBOARD	OUTBOARD
Hydra XD + HG	1 x 152610	1 x 15267
Micro Spline	1 x 152610	2 x 6802

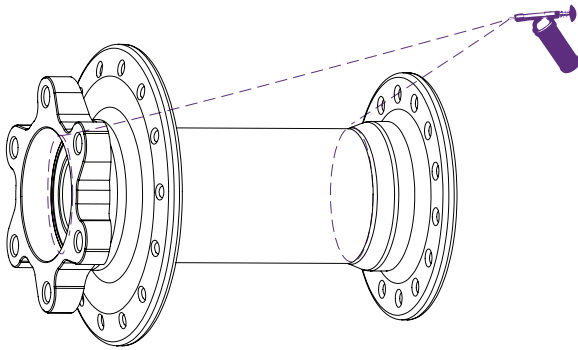

7.2 Front Endcap Installation - Coat the seal of the bearing with a film of **marine grease** before pressing the endcaps into the hub.

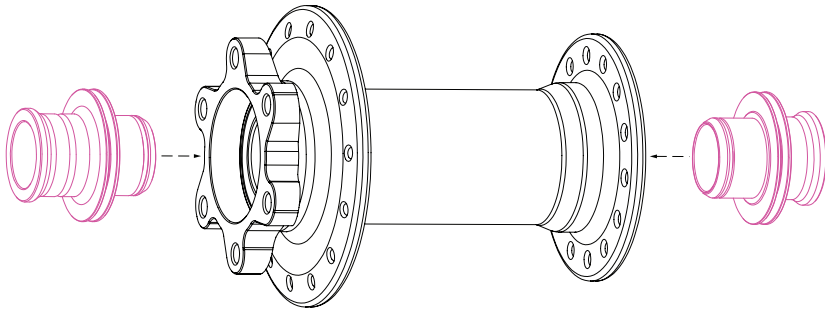

Coat the o-rings inside the **endcaps** with grease.

Marine grease will create a membrane that will help keep your bearings free from contamination.